

SHADING DEVICE CALCULATOR: A TOOL FOR SUSTAINABLE, ENERGY-SAVING, CLIMATIC BUILDING DESIGN

Dr. Tarek S. Elhinnawy
Prof. Dr. Ossama A. Abdou
Center for Building Environmental Studies and Testing (C-BEST)
15 El-Shibany Street, Almaza, Cairo

ABSTRACT

One method used to control the amount of sun coming through a window is the provision of appropriate shading devices. Their efficiency depends on placement and dimensions. In this paper a scientific method is presented that aids in the design of efficient shading devices for windows at any orientation. A computer program has been developed by the authors to address this issue specifically. The computer program is interactive, prompting the user to provide minimal geographic and climatic data. The program processes this information and presents results graphically as well as numerically. The sun path diagram for the locality under investigation along with the overheated period is plotted accurately. Profile angles for the respective shading devices are determined, whereby dimensions and shading efficiency of the devices are calculated accurately for energy-efficient design.

INTRODUCTION

To meet human needs for natural light and outside views, buildings are designed with large window openings, making proper orientation and sun control very important. Solar radiation affects air-conditioning capacity and solar energy can supplement the heat source in winter. Thus it is increasingly important to know and understand the sun's effect on the design and engineering of a building. Paramount in this is knowledge of the sun's apparent position.

The seasonal positions of the sun are universally known in general terms. It is directly over the equator about March 21, the vernal equinox, and thereafter it appears farther north each day until it reaches its zenith above the Tropic of Cancer about June 21 (the summer solstice in northern latitudes). Then the sun appears a little more southerly each day, rising above the Equator about September 21 (the autumnal equinox) and reaching its most southerly point over the Tropic of Capricorn about December 21 (winter solstice).

This general information is insufficient to determine the sun's effect on a specific structure in a particular location. To know how the rays will strike a building and how far the rays will penetrate through the opening; to shade certain areas and irradiate others; to know the effect of heating; to effectively use daylighting to reduce the use of artificial lighting; to know the effect of solar energy on air-conditioning capacity and operation; we must have the following information:

1. The angle of the sun above horizon (altitude).
2. Azimuth of the sun, or its direction.
3. The angle of incidence of the sun relative to the surface being considered.

The altitude angle is the angle of the sun above the horizon, achieving its maximum on a given day at solar noon. It is worthy to note that there is symmetry around solar noon. The azimuth angle is the directional angle of the sun's projection onto the ground "plane" relative to south. Altitude angles are high in the summer and low in the winter – with the difference between highest summer and lowest winter noon altitudes being roughly 47 degrees. ASHRAE (2001) provides all necessary equations relevant to this information. These must be known for a particular surface, no matter what its orientation, for at least several hours of each day studied.

SOLAR POSITION

If the sun is to be utilized in a proposed building for either heating or lighting, it is necessary to determine its availability on the site. Surrounding objects such as other buildings, trees, and landforms all act as solar obstructions by blocking either direct sunlight or portions of the sky as visible from the building location. Because of the potential effect on heating, cooling and illumination, and because of its directionality, the position of the sun is of particular interest to the architectural designer.

As pointed out above, the position of the sun in the sky can be described by its altitude angle and its azimuth angle. Both are function of site latitude, day of the year, and solar time of the day. While azimuth and altitude angles can be determined mathematically or from tables in standard reference books, these numerical values are not directly usable in the architectural design process. Instead, two graphic methods are particularly applicable in daylighting, passive solar, and shading design. These are sun path diagrams and sundials.

SOLAR RADIATION

In the spectral composition of solar radiation there are different zones that directly affect humans. These regions can be conveniently categorized into three main divisions according to their wavelength (Fig. 1) (Koenigsberger et. al., 1974). The shortest waves are in the ultra-violet (UV) region (erythemal radiation); although these represent only approximately 3% of the entire solar spectrum, they have specific importance for their therapeutic value. Since ordinary glass is opaque to these wavelengths, they are filtered out automatically.

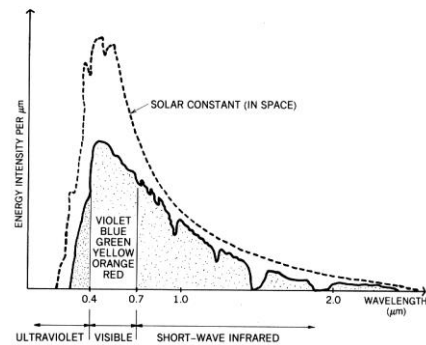

Fig. 1 Solar Spectrum at the Earth's Surface

The middle band of the spectrum is the visible (light) range. This range represents circa 44% of the solar spectrum. Here the function of the window is to admit sufficient illumination and yet reduce glare. This can be regulated most conveniently at the inner side of the building envelope. Because of the relatively easy methods of light control, vulnerability to heat impacts becomes much more important from the point of view of environmental comfort.

Radiation control should, then, focus on the heat waves, which lie mostly in the long-wave infrared (IR) range, representing roughly 53%, i.e., the largest portion of the spectrum. Therefore, it makes sense to treat the question of shading and sun control from the standpoint of heat regulation. Here, the problem asks for diametrically opposite functions from the glass panel; for maximum reception of welcome solar heat in winter (underheated period), and the exclusion of excessive heat penetration in summer (overheated period). Fortunately, in this seemingly controversial situation, the sun itself offers aid by traveling different paths in the different seasons. This circumstance of solar mechanics invites a degree of automatic seasonal control. The basic architectural means to utilize these advantages are the building shape and orientation. The building envelope itself has a decisive role, according to its opaqueness or transmittance, absorption or reflectance of the solar rays.

The materials, which provide a screen between the indoor environment and the natural outdoor environment, offer rich possibilities for visual expression. With them new components are added to the architectural vocabulary. Many materials only elaborate the surface, others invite a rich play of

light and shadow or add to the spatial composition, while some constitute their own architectural entities.

SHADING DEVICE DESIGN APPROACH

External window shading is an excellent way to prevent unwanted solar gain. External shading devices are more effective than interior devices because they stop solar gain before it enters the building space. External shading can be provided by natural landscaping or by building elements such as awnings, overhangs, trellises, shutters and vertical louvers. Some shading devices can also function as reflectors, or light shelves, which bounce natural light for daylighting deep into building interiors

Generally speaking, shading devices, whether vertical or horizontal, straight or slanted, fixed or movable, are elements independent of direct scale, leaving only the geometrical relationships to be their masters. As building skin compositions, shading devices offer large variations. This diversity is not incidental. Their character is representative of positive functions, as the dominant patterns are basically designs of their specific uses. Some patterns let the air movement through, and provide shade with more or less privacy. Some use the wind to cool the wall and defend it by half shade. Patterns might be geometrical or use the fluid play of clear-obscure surfaces accentuated by light.

Rule-of-Thumb Approach

It is generally agreed that the principle of thermal solar control is to let the sun's energy into the building during the winter and to intercept it in the summer. This simplified principle gained wide acceptance in architectural practice, prescribing overhangs according to the winter and summer solstice angles.

This method, while basically valid with rule-of-thumb effectiveness, was born as a response to a building's need of summer protection; it provided applicable solutions only to the south side of the building, leaving the other sides to the discretion of the designer. Further, the provision of full shade according to the solstice date – June 21st – while the warmest days usually occur around the end of July or the beginning of August leaves some doubt as to the validity of this method. Something has to be done to deal with this annual time lag of roughly 40 days between the summer solstice date and the warmest day date. In tropical zones, where undoubtedly longer periods require full shade protection, the shortcomings are more evident (Olgay and Olgay, 1957).

Scientific Approach

With this in mind, the requirements of solar control should be rephrased so as to have the sun strike the windows (and the rest of the building envelope, if needed) and allow the desirable heat energy into the building at all times when the weather is cool. Conversely, the building should be properly shaded at all times when it is hot. On this principle a balanced solar heat control can be achieved.

In order to accomplish this, one has to clarify and define what constitutes “cool” and “hot.” The yardstick to these relative measures is human physiological reactions to surrounding thermal environment. For any given locality the climatic conditions, mainly the air temperature, give an index for outlining cold and hot periods, which can be designated as the *underheated* and *overheated* periods. The overheated period is the one when shading is needed. With these divisions one is in the position to know when the sun should be intercepted. To know where the specific positions of the sun are during overheated periods, the sun path diagram can give a positive answer based on the sun's angles. The determination of the *when* and *where* gives us the data necessary to answer the question *how*.

The optimum dimensions of a shading device depend upon the relative importance of heating and cooling in a building, on the sensitivity of the work performed in the space to glare, on the orientation of the windows, and upon the latitude of the site. An overhang sized to block all direct summer sun will also provide some window shading in spring and fall when penetration of sunlight is welcome. Conversely, an overhang sized to allow maximum sun exposure in the winter will allow solar gain during hot days of early fall.

Profile Angles

The angle of shade cast on a particular surface resulting from the combined effect of solar altitude and solar-wall azimuth is known as the “profile” or shade angle. Profile angles can be calculated for any latitude, date, solar time, and surface orientation. It is an angle in a plane perpendicular to the surface being evaluated, and it ultimately determines the protrusion of the device from the window plane. A vertical profile angle characterizes a horizontal shading device, e.g., a long horizontal projection from the wall above the window, and is measured on a vertical plane normal to the elevation considered. A horizontal profile angle characterizes a vertical device, also known as fin, and it is the difference between the solar azimuth and wall azimuth. Thus, the performance of shading devices is measured by these two angles. In fact, they indicate the limit, beyond which the sun would be excluded, but within which the sun would reach the point considered. By knowing this angle, shadow heights can be determined based upon the width of the projection of the respective device (see Figs. 2a and b).

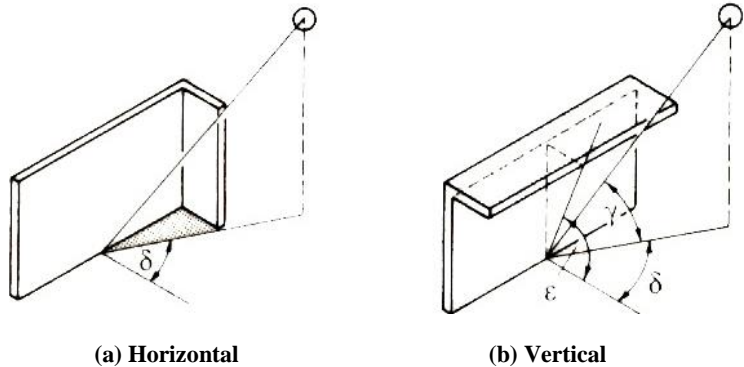

Fig. 2 Profile Angles

The distinction between solar altitude angle and vertical profile angle must be clearly understood. The first describes the position of the sun in relation to the horizon; the second describes the performance of a shading device. Numerically, the two coincide when the sun is exactly opposite the wall considered. For all other cases, that is, when the sun is sideways from the perpendicular, the vertical profile angle is always larger than the solar altitude angle for which it would still be effective. And, since we are dealing here with angles, narrow blades, whether horizontal or vertical, with close spacing may give the same profile angle as broader (i.e., deeper) blades with wider spacing.

Using the shadow angle protractor, the “shading mask” of a given device can be established. For vertical devices this is the characteristic sector shape, as shown in (Fig. 3). The shading mask of a horizontal device is of a segmental shape as shown in (Fig. 4). To exclude a low angle sun using a horizontal device, it would have to cover the window completely, thereby permitting a view downwards only.

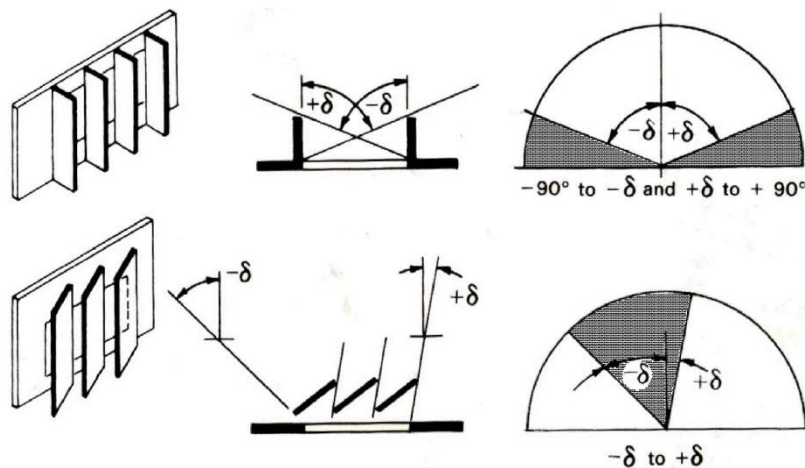

Fig. 3 Vertical Shading Devices

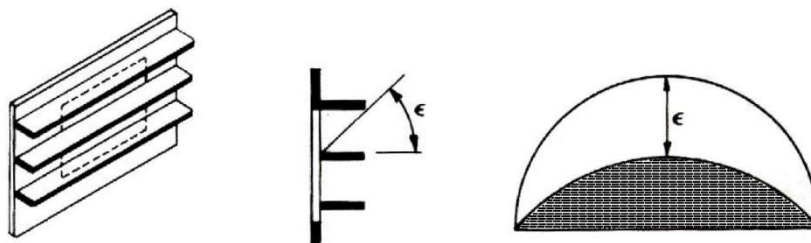

Fig. 4 Horizontal Shading Devices

In order to determine the distance at which a horizontal device should be extended, the sun path diagram for the locality under consideration can be used with the overheated period plotted on it. Shading times for the particular device (dates and hours) can be read off directly. This method obviates the need to establish solar position angles a priori. The overheated period is considered any period with a dry-bulb temperature exceeding a predetermined temperature value depending on overall climatic conditions of the locality being studied. Vertical fins can be provided to ensure exclusion of the sun from the sides.

Defining the Overheated Period

Abdou (1987) has shown that the upper day comfort limit can be set at 30 deg C. This seemingly high limit is possible in hot, dry regions because of the low humidity and vapor pressure which prevent discomfort due to the clamminess which is experienced in still air at this temperature in more humid regions. The desired relative humidity range is 25 -55%. Another factor has to do with the fact that people in the tropics and subtropics are more acclimated to hot environments than those living in moderate climatic regions (Lee, 1963; Fanger, 1972). The upper day comfort temperature of 30 deg C reflects the indoor climate of the building, i.e., under shade conditions. Therefore, it is assumed that no or minimal direct interaction occurs between solar radiation and internal temperature. In locations experiencing more humid conditions, the upper day comfort limit will certainly be reduced accordingly.

Given the above, as a first step in the design procedure, it must be decided when shading is necessary, at what times of the year and between what hours of the day. The best guide to this is the

determination of the overheated period as measured by comfort levels. The cut-off temperature for day comfort limit should be determined. However, it is worth noting that radiation heat gain can never be eliminated completely; therefore, it is advisable to define the overheated period for the purpose of shading design, by a temperature closer to the lower limit of the comfort zone.

COMPUTER PROGRAM

Because time-consuming trigonometric methods are needed for calculation, a quick method of obtaining solar angular values is necessary. But such a method must be applicable to all latitudes and give all necessary values for all possible time and orientation conditions. Based on the ASHRAE equations, an interactive computer program using Visual Basic has been developed by the authors to facilitate such calculations. Results are presented graphically quickly and accurately.

Elements of the Computer Program

Location Library

A built-in library containing basic, but crucial, information on the geographic coordinates of several major cities in Egypt is provided. The basic ingredients of the library include geographic latitude of the respective city, as well as related monthly temperature values as indicated below. A built-in flexibility in the program allows further addition of geographic locations at any time, provided that their geographic latitudes are known, and their climatic data are available.

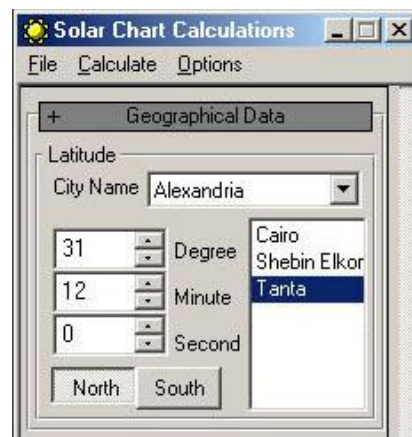

Fig. 5 Interface of Location Library

Temperature Values

Of particular relevance is the data reflecting monthly temperature values. They are important because they create a profile that establishes when it is hot and when it is cold. Hence, overheated and/or underheated periods of the year can be established. As referred to earlier, the overheated period is that period when solar radiation is not welcome, i.e. when its level is bothersome, and should be avoided. Since the available temperature values are monthly-based they cannot be readily used to construct the overheated and underheated periods. These have to be converted to hourly or at least bi-hourly profiles to reach some accuracy. This has been accomplished using a simple statistical method as described by Perkins (1984).

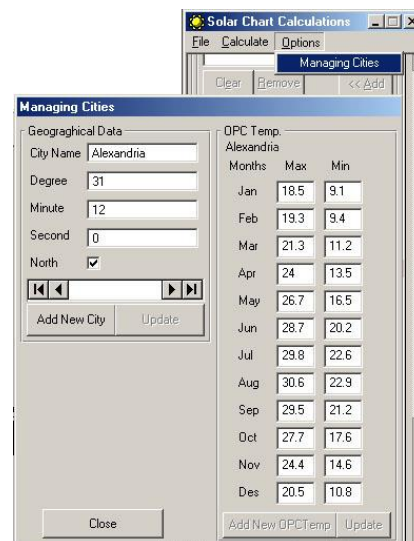

Fig. 6 Input Values of Monthly Temperature

Developing the Sun Path Diagram

With the aid of the ASHRAE equations it is easy to determine the sun path diagram of any city by establishing the exact position of the sun for the city under consideration at any part of the day in any month of the year. The developed computer program constructs the sun path diagram for any locality accurately.

The sun path diagram is a two-dimensional chart representing the apparent motion of the earth around the sun. However, the changing position of the sun in the sky from day to day is most easily visualized if the point of observation is imagined to be stationed on a flat surface tangential to the earth and surrounded by a hollow hemisphere, the sky vault, on which the sun moves in a circular path (Fig. 7). This is actually how the sun appears from the earth's surface, moving in an arc over the sky. The tangential surface is the horizon, and its imaginary intersection with the sky vault is called the horizon line. The two-dimensional projection of the imaginary sky vault is shown in (Fig. 8). On the resulting diagram the horizon line appears as a circle, and the sun path as various curves depending on the latitude.

The hour lines of the same time of day on the surface of the sky vault are great circles going through the intersection point on the axis of the cones with the vault, which represents the pole of the sky. It is worth noting that the solar noon line lies exactly on the north-south direction.

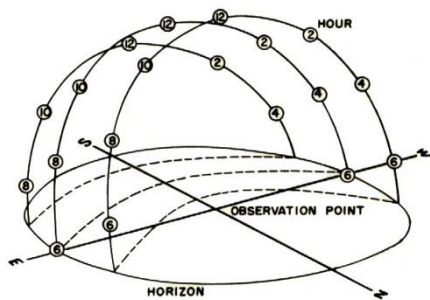

Fig. 7 Sky Vault with the Sun Paths

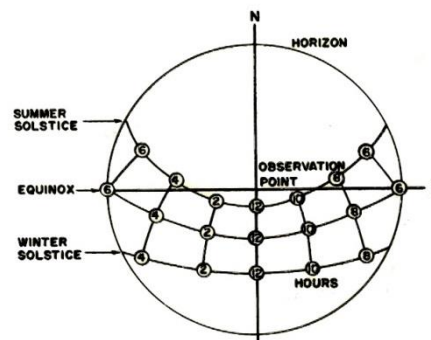

Fig. 8 Projected Diagram of the Sky Vault (Sun Path Diagram)

With the computer program at hand there are two options for constructing the sun path diagram for any geographic latitude. The program allows the user to select either the standard (default) chart with predetermined dates, or opt for a customized chart. In the latter case, the user can specify any particular dates and range of hours that satisfy his requirements for design and/or analysis.

Using the Sun Path Diagram

As indicated earlier, the curved lines on the sun path diagram represent the position of the sun on the earth's surface, as seen from above, at that latitude and date. The dark lines radiating from the North Pole represent solar time at one-hour interval, with the light lines positioned at fifteen-minute intervals.

In the center is a plan view showing the window under study. It can be placed at any desirable orientation by just rotating the plan. Figure 9 shows the graphic interface with a window oriented southeast. Buttons allow scrolling up and down to change window orientation at anytime. These changes are reflected instantly graphically on the sun path diagram.

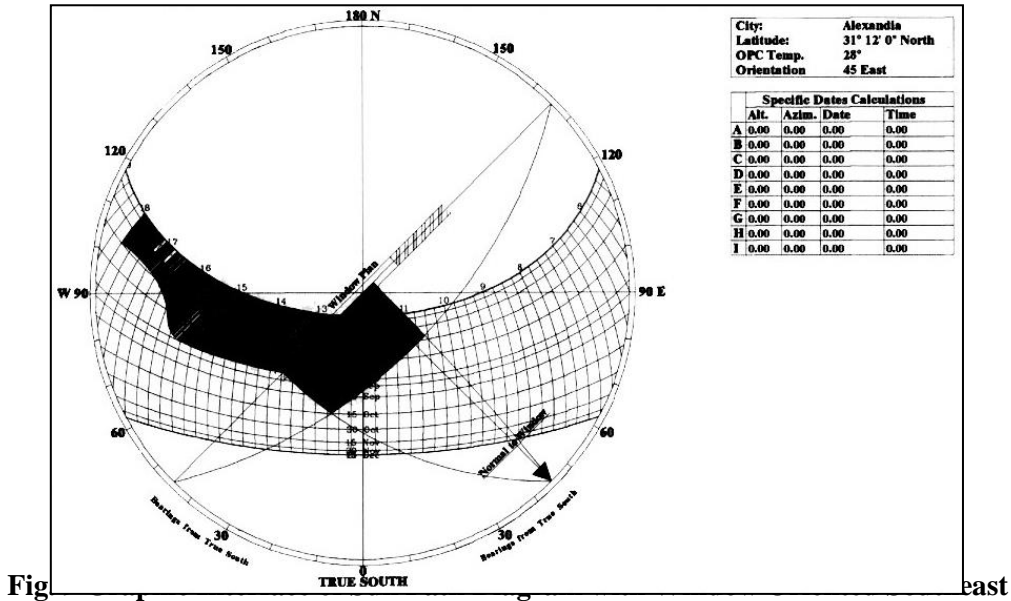

Location and Geometries of Shading Devices

There are generally two geometries of sun control devices, the horizontal overhang and the vertical fins. The overhang is most effective for windows facing south or nearly so. But, its efficiency depends on placement and dimensions. The developed computer program allows the simulation of either device type separately or combined.

Sizing the Shading Devices

The computer program presented here evaluates the effect on vertical glazing from building projections (i.e., overhangs and fins) for windows in the walls. The user has the option of navigating the profile angle to match the overheated period spread on the sun path diagram. Since the program is interactive, real-time changes can be seen immediately and evaluated instantly.

In the program, the path to control information about shading is begun by clicking on the routine entitled *Shading Mask*. The user is then prompted to define the cut-off temperature of comfort level, from which the overheated period is calculated. Immediately, the overheated period is plotted onto the sun path diagram. For the purposes of the computer program at hand, the minimum cut-off temperature is 0 deg C, although this is highly unlikely to provide any practical need. The uppermost cut-off temperature is the highest attainable temperature reading reachable in the locality under consideration.

Then, the user is prompted to start shading design by specifying the orientation of the window in the space provided right to it. Arrows allow scrolling up or down to the desired orientation with an increment of one degree (up or down). Based on the plotted overheated period, the user is prompted to specify the profile angle and insert the dimensions of the desired window. Refer to the diagram in (Fig. 10) to see the definition of shading angles and dimensions. A dialog box will then appear that gives

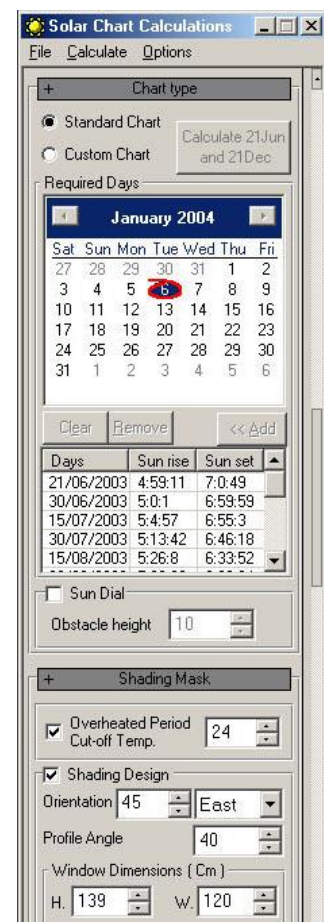

Fig 10 Definition of Profile Angle and Window Dimension

the user the option to design a horizontal device above the window or vertical fins on either side of the windows. Two geometries can be given, left and right (as seen looking inward from the window).

Since both horizontal and vertical shading devices need extensions beyond the physical size of windows to block solar rays (for example, see Fig. 11), the program calculates such extensions and gives the user the option of either extending the device along the same plane of the device or, instead, design vertical sides, by merely defining the right and left edge angles. Hence, the user can define his/her own shading geometries for overhangs or fins using either dimensions or cut-off angles.

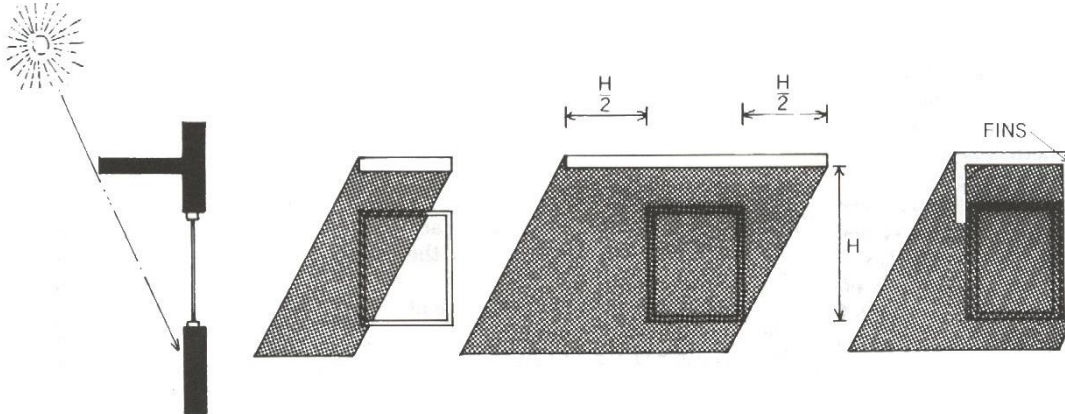

Fig. 11 Extensions of Overhangs beyond the Physical Size of Window

Another advantage of the program is the fact, that, based on the input information given by the user a graphic output showing the generated shading device(s) is given directly alongside the digital output delineating the dimensions of the designed devices (see Fig. 12). Based on the cut-off temperature selected by the user, the related overheated period is calculated and plotted instantly onto the sun path diagram. If the user opts to change the cut-off temperature limit anytime, he can do so easily by scrolling up or down the assigned buttons. The change in the plotted overheated period occurs automatically. Here, a step-by-step visualization of the relationship between the overheated period and the shading mask is made possible. Any mistakes can be detected and rectified immediately. Again, Figure 9 shows the graphic interface. In order to be able to evaluate efficiency of the design, shading ratio is calculated as displayed for each device designed. A shading ratio of 100% indicates that the shading mask of the designed or proposed shading device covers the overheated period completely without exceeding it.

Evaluation of Shading Efficiency

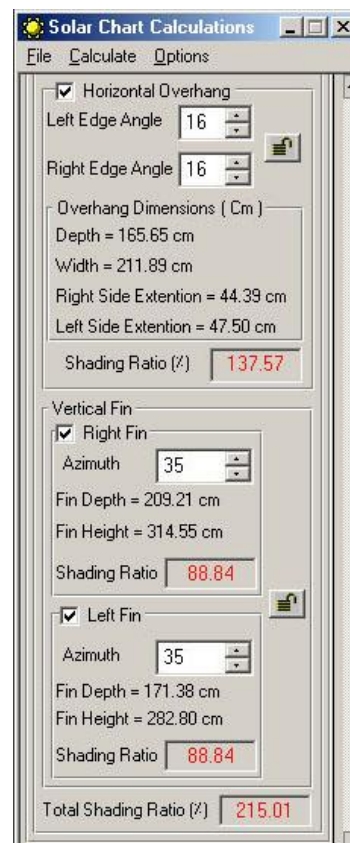

Fig. 12 Digital Output of Shading Device Dimensions and Shading Ratio

Shading efficiency can be evaluated at two levels. First, through the sundial and second, through the efficiency of the shading device itself. In order to evaluate efficiency of the designed devices, a routine has been included that calculates the shading efficiency. This can be accomplished for each separate device whether horizontal or vertical. Finally, the shading efficiency of combined horizontal and vertical devices are calculated taking into account any overlaps that may occur from individual shading masks (reference is made to Fig. 9). The criteria for measuring shading efficiency most obviously relate to the extent that the overheated period is covered.

If a shading device is designed to exclude solar radiation exactly only during the overheated period then a 100% shading efficiency is attained. A percentage point lower than this means that the solar radiation will enter the windows at unwanted times. A percentage point higher than 100% indicates that the shading device will prevent solar radiation to enter windows during underheated periods rendering the device less efficient.

CONCLUSIONS

Although shading of the whole building is beneficial, shading of the window is crucial. To prevent unwanted solar heating, a window must always be shaded from the direct solar component and often also from reflected components.

The type, size and location of a shading device will therefore depend on solar angular relationships with the window in terms of solar altitude and azimuth.

By transmitting this information to scaled sectional and plan drawings, it is possible to determine the proper length and width of a shading device to completely shade the window during the overheated period, and let in solar radiation during the underheated period. This is facilitated by the use of a computer. Therefore, an interactive computer program has been developed by the authors to establish the proper dimensions of horizontal and vertical shading devices and compute their shading efficiency based on information defining the overheated period, i.e., when the solar radiation is to be excluded from the building.

REFERENCES

- Abdou, O. (1987). *The Impact of Solar Energy Utilization on Multi-story Apartment Houses in Hot Dry Climates*, Ann Arbor, MI: University Microfilms, Inc.
- ASHRAE. (2001). *Handbook of Fundamentals*. Atlanta, GA: American Society for Heating, Refrigerating and Air-conditioning Engineers.
- Fanger, O. (1972). *Thermal Comfort: Analysis and Applications in Environmental Engineering*, Copenhagen: Danish Technical Press.
- Koenigsberger, O., Ingersoll, T., Mayhew, A. and Szokolay, S. (1974). *Manual of Tropical Housing and Building, Part 1: Climatic Design*, London: Longman Group, Ltd.
- Lee, D.H.K. (1963). *Physiological Objectives in Hot Weather Housing*, Washington, DC: Dept. of Housing and Urban Development.
- Olgyay, A. and Olgyay, V. (1957). *Solar Control and Shading Devices*, Princeton: Princeton University Press.
- Perkins, D. (1984). "Heat Balance Studies for Optimizing Passive Cooling with Ventilation Air," *ASHRAE Journal*, February